

TFI F-1600 Mud Pump

TFI F-1600 mud pumps are designed and manufactured according to API 7K.

1. Specifications

Max. Input Power:	1600 HP
Rated Pump Speed:	120 SPM
Max. Fluid Cylinder Liner Bore:	7"
Stroke Length:	12"
Gear Type / Ratio:	Herringbone / 4.206:1
Pinion Shaft Diameter:	8.5"
Suction Flange:	12"
Discharge Flange:	5-1/8"
Valve and Valve Seat Model:	API No.7
Weight:	56,663 lbs
Length:	174.25"
Width:	74.02"
(W/O Strainer Block and Pulsation Dampener)	
Height (W/O Pulsation Dampener):	79.72"

F-1600 Mud Pump Sizes and Ratings

Liner size			Displacement				Maximum Pressure		Pump SPM	Input HP
Dia.	Stroke		Per Stroke		Per Minute		Psi	MPa		
in.	in.	mm	Gal.	Lit.	Gal.	Lit.				
7	12	305	6.15	23.4	738	2804	3292	22.7	120	1600
6-3/4			5.48	20.8	658	2500	3698	25.5		
6-1/2			4.86	18.5	583	2215	4133	28.5		
6			4.27	16.2	512	1946	4742	32.7		
5-1/2			3.73	14.2	446	1695	4974	34.3		
5			3.21	12.2	385	1463	4988	34.4		

Note: Mechanical Efficiency 90%; Volumetric Efficiency 100%

2. Key Features

- A. Every mud pump is fabricated with a high strength, heat treated steel frame;
- B. Pinions, gears, crankshafts and fluid end modules are made from high strength, heat treated alloy steel;
- C. TFI can provide complete pump packages, including prime movers, controls, manifolds, piping, and accessories;
- D. The cross heads and guides are wear resistant and replaceable;
- E. The suction stabilizers are included in all units;
- F. Internal gear pump provides positive pressure lubrication to power end;
- G. TFI mud pumps are rated for 24 hour-a-day continuous duty;
- H. Complete range of replacement parts is available in our service facility at Brookshire, TX.;

3. Scope of Supply

- A. F-1600 Mud Pump × 1 set;
- B. Pistons and Liners × 3 sets;
- C. Accessory Manifold × 1 set;
- D. KB75 Pulsation Dampener × 1 set;
- E. Discharge Assembly and Strainer Block × 1 set;
- F. Shear Relief Valve × 1 set;
- G. Liner Wash System × 1 set;
- H. Fittings × 1 set;
- I. Operation manuals, Parts List and Certificates × 1 set;
- J. Optional-Recommended Spare Parts;

4. Overall Dimension Schematic
 (Measurements are in inches)

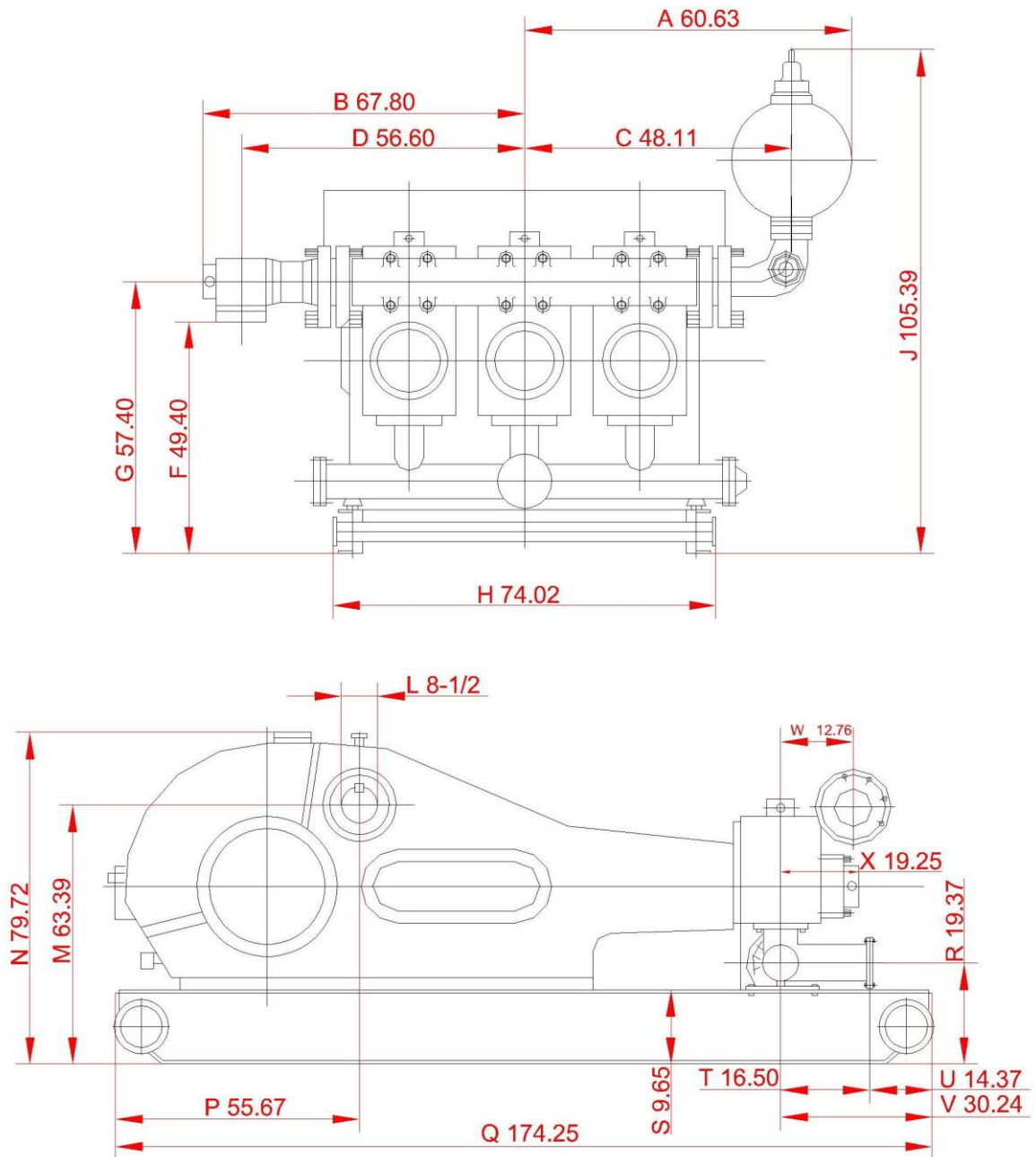

5. Recommended Spares List

No.	Model Number	Description	Specification	Qty.
1	TFI33001-09	Gasket		2
2	TFI36001-13	Gasket		1
3	TFI36001-19	Gasket		2
4	TFI36001-16	Gasket		2
5		Rubber Rod	40 × 10 × 5800	1
6	TFI36001-02.03	Seal Washer		2
7	TFI36001-03.05	Gasket		2
8	TFI36001-03.10	Gasket		2
9	TFI36001-03.12	Gasket		2
10	TFI36001-03.08A	Oil Seal		2
11	TFI36001-04.21	Oil Seal Ring		3
12	GB3452.182	O-Ring	Dia.199 × 3.55	3
13	TFI36001-04.08A	Double Lip Oil Seal	5" × 6.25" × 0.625"	6
14	GB3452.1-82	O-Ring	Dia.125 × 7	3
15	TFI36001-04.15	Gasket		3
16	GB3452.1-82	O-Ring	Dia.160 × 7	3
17	TFI36001-04.17	Lower Guide		3
18	GB3452.1-82	O-Ring		3
19	TFI33001-05.16A	Valve Spring		3
20	GB3452.1-82	O-Ring	Dia.95 × 5.3	3
21	TFI36001-05.15	Bushing Gasket		3
22	TFI36001-05.08	Cover Gasket		3
23	TFI33001-05.16A	Valve Spring		12
24	TFI36001-05.13	Valve Cover Gasket		3
25	TFI36001-05.04.00	Connection Tube		3
26	GB3452.1-82	O-ring	Dia.200 × 7	3
27	TFI36002-05.08	Bend Pipe		3
28	TFI36001-05.10	Connector		3
29	TFI36001-05.11	Elbow		3

30	TFI33001-05.12	Valve Rod Guide		3
31	TFI33001-05.20A	O-Ring		3
32	GB3452.1-82	O-Ring	Dia.185 × 7	3
33	L=1500	Hose	Dia.22 × Dia.37	1
34	GB1171-74	V-Belt	A3708	2
35	L=750	Hose	Dia.38 × Dia.35	1
36	GB3452.1-82	O-Ring	Dia.165 × 7	1
37	T58-5002	Ring Gasket	R44	3
38	T58-5001	Sealing Ring	R39	1
39	TFI33002-03.00	Bladder		1
40	TFI33003-11	Shear Pin		6

6. Product Picture

